

顶板高压定向水力致裂技术

- 定向致裂原理
- 高压定向致裂装备
- 高压定向致裂技术

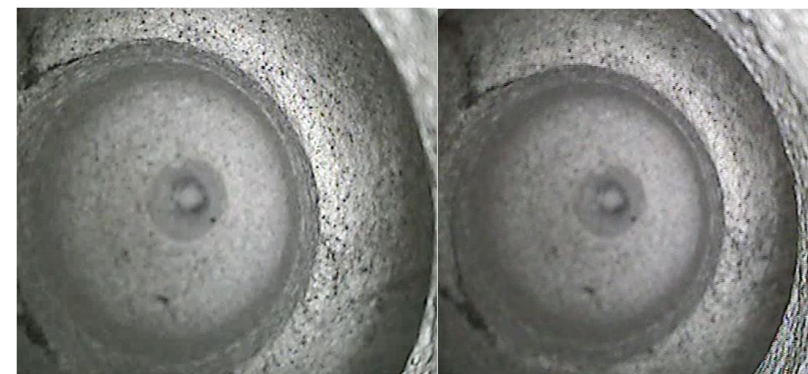
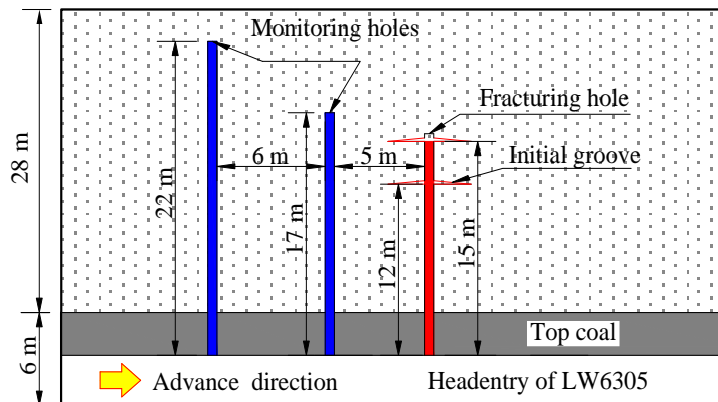
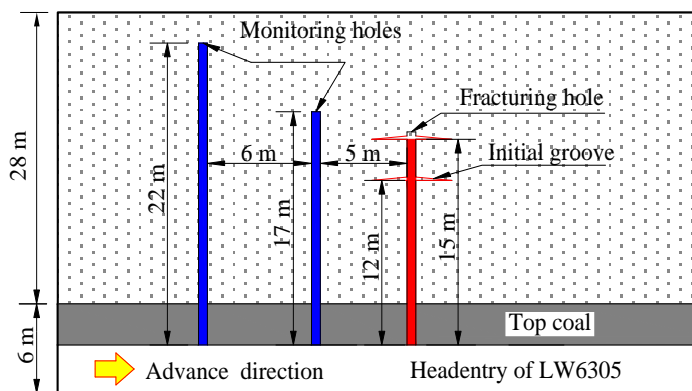
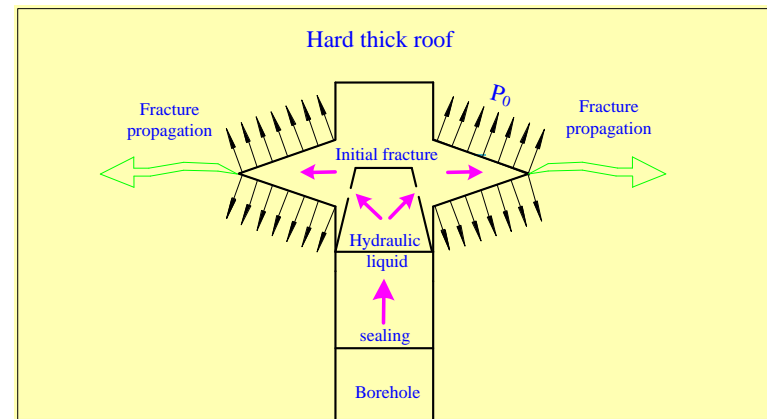

1#切槽窥视图

2#切槽窥视图

8.1) 高压定向水力致裂原理



State Key Laboratory of Coal Resources and Safe M



➤ 高压水力定向致裂技术 (2006)

$$P = 1.3(P_z^* + R_r)$$

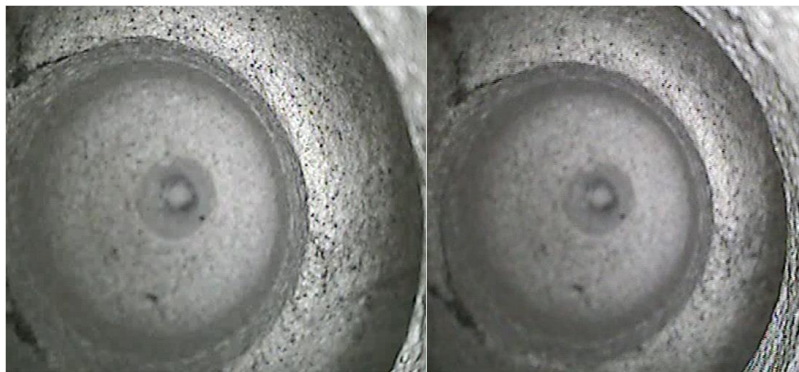
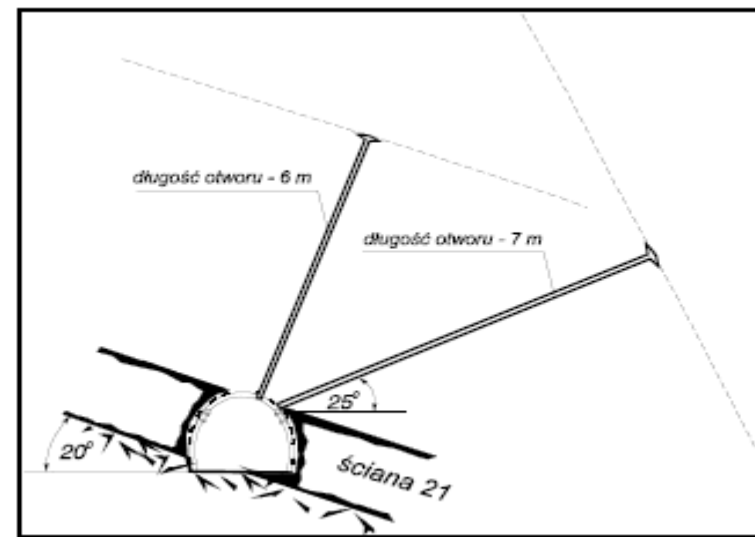
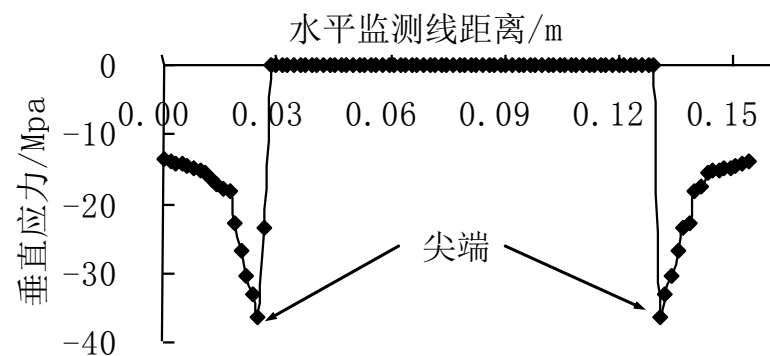
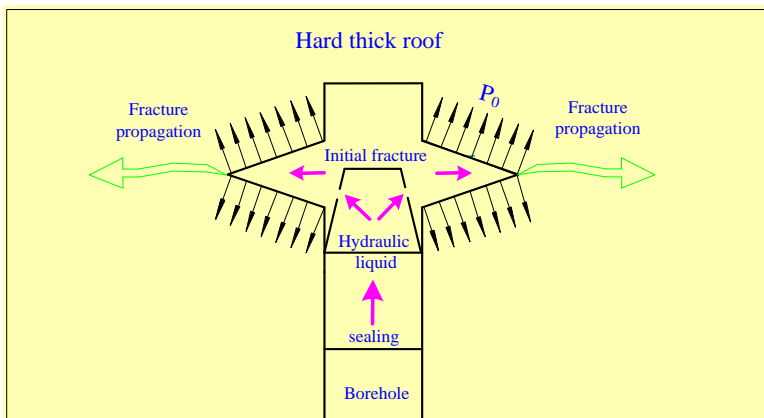

1#切槽窥视图

2#切槽窥视图

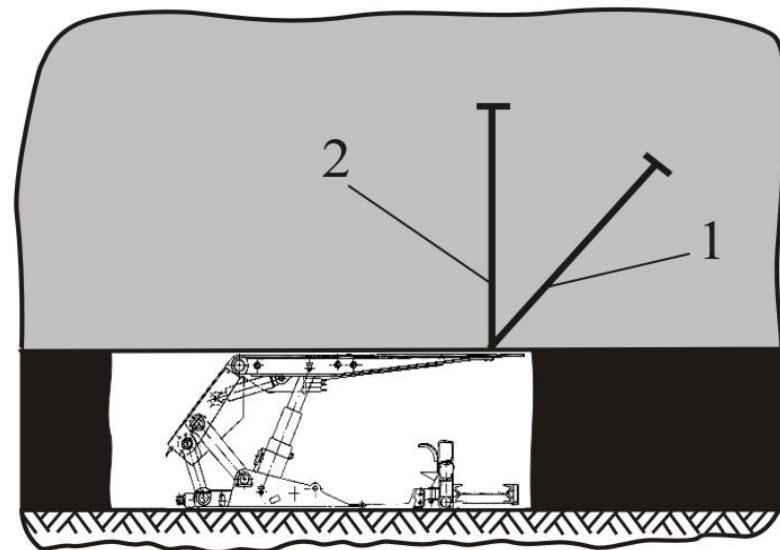
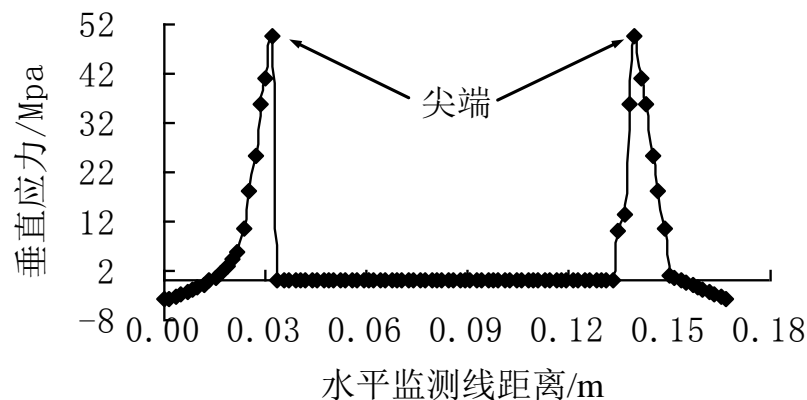

□ 山东省科技进步三等奖 (2013)

8.2) 高压定向水力致裂装备



State Key Laboratory
of Coal Resources and Safe Mining

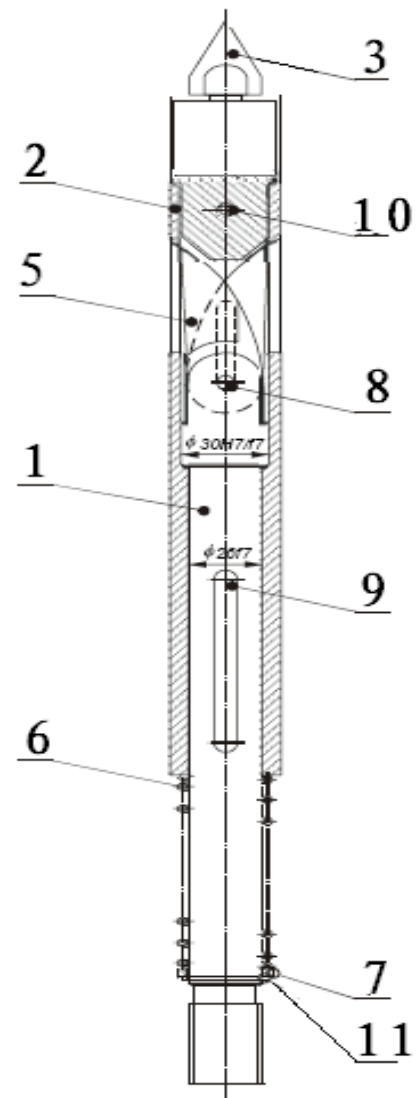

封孔器



刀具



压力管



钻孔窥视仪

8.3) 高压定向水力致裂技术



State Key Laboratory of Coal Resources and Safe M



应用：防冲、强制放顶、护巷

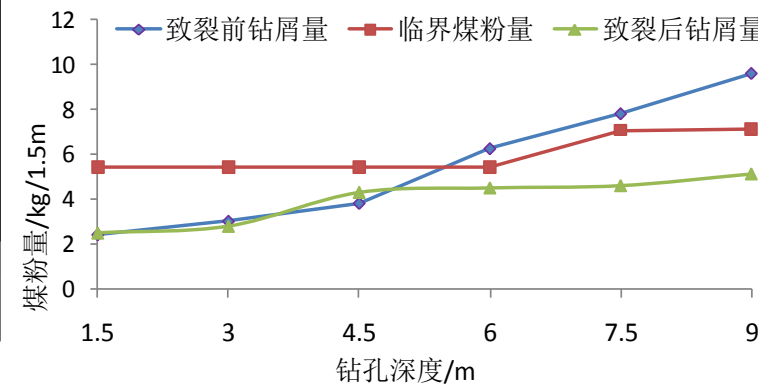
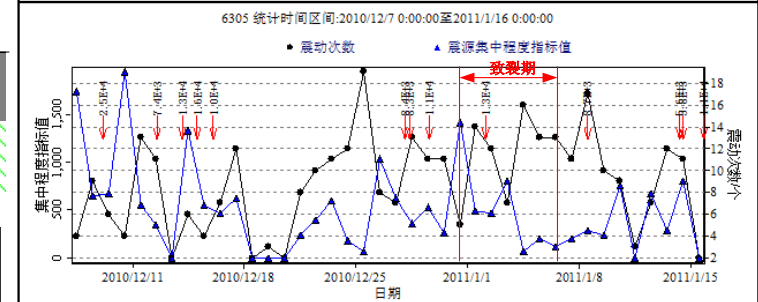
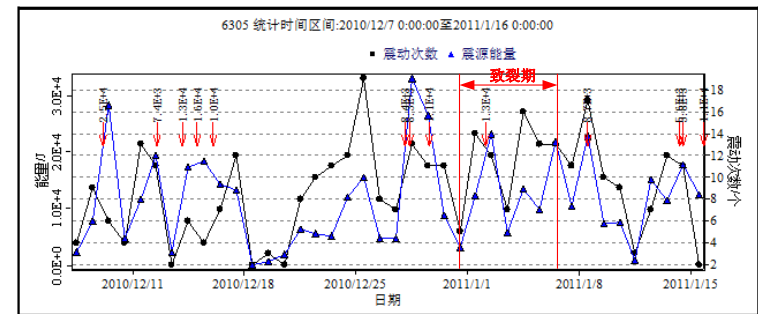
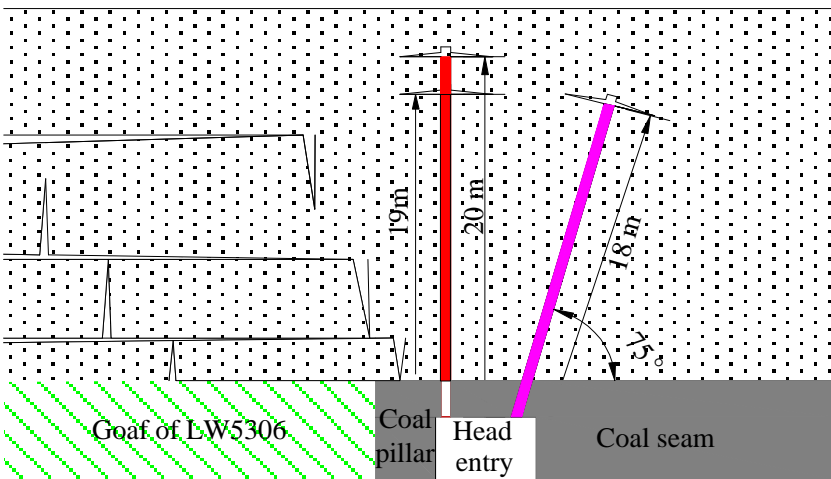
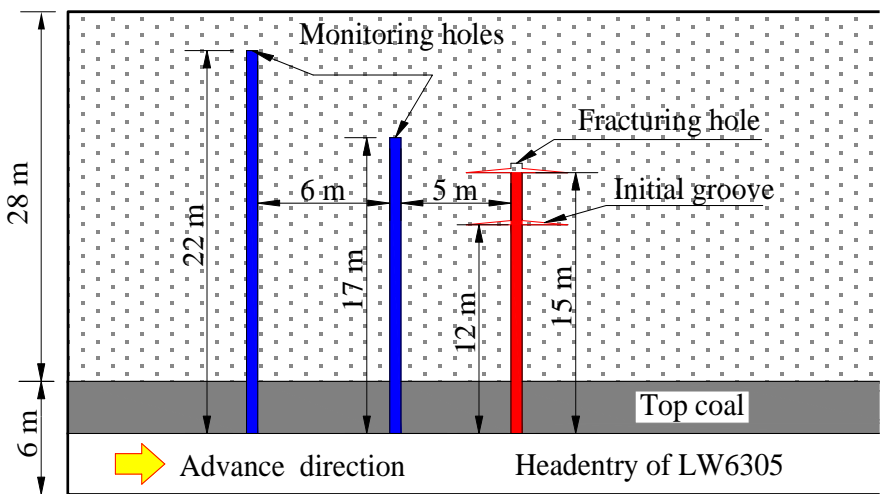
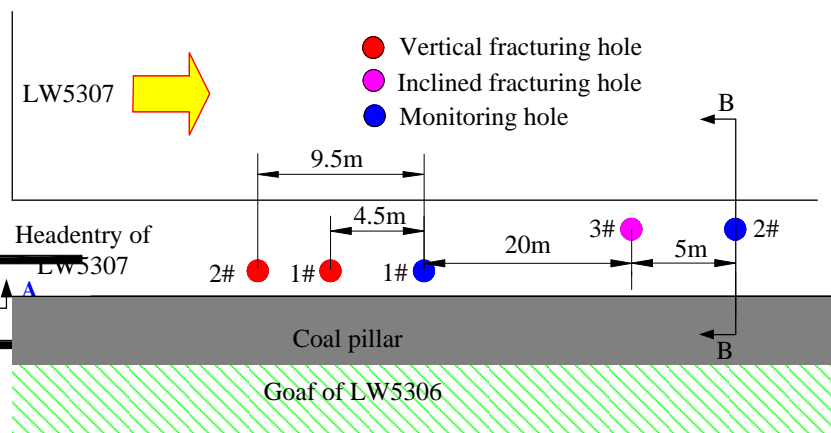
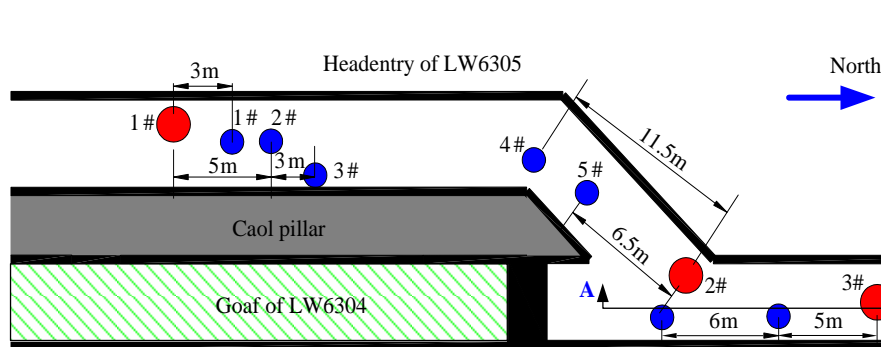

8.3) 高压定向水力致裂技术



State Key Laboratory of Coal Resources and Safe Mining



□ 高压定向水力致裂——防冲、护巷

